

Technische Daten

Allgemeine technische Informationen	
Empfohlene Brennstoffmenge	15 kg
Querschnitt der Verbrennungsluftöffnung	220 cm ²
Verbrennungsluftstutzen	2 × Ø 125 mm
Freie Glas- Sichtfläche	2 226 cm ²

Menge	Volumenstrom		Druckverlust
3 kg	28,2 m ³ /h	0,008 m ³ /h	0,1 Pa
4 kg	37,6 m ³ /h	0,010 m ³ /h	0,4 Pa
5 kg	47,0 m ³ /h	0,013 m ³ /s	0,9 Pa
6 kg	56,3 m ³ /h	0,016 m ³ /s	1,4 Pa
7 kg	65,7 m ³ /h	0,018 m ³ /s	2,0 Pa
8 kg	75,1 m ³ /h	0,021 m ³ /s	2,8 Pa
9 kg	84,5 m ³ /h	0,023 m ³ /s	3,6 Pa
10 kg	93,9 m ³ /h	0,026 m ³ /s	4,5 Pa
11 kg	103,3 m ³ /h	0,029 m ³ /s	5,6 Pa
12 kg	112,7 m ³ /h	0,031 m ³ /s	6,7 Pa
15 kg	140,9 m ³ /h	0,039 m ³ /s	10,7 Pa
20 kg	187,8 m ³ /h	0,052 m ³ /s	19,4 Pa

GT2 63/51 / Zuluftanschluss

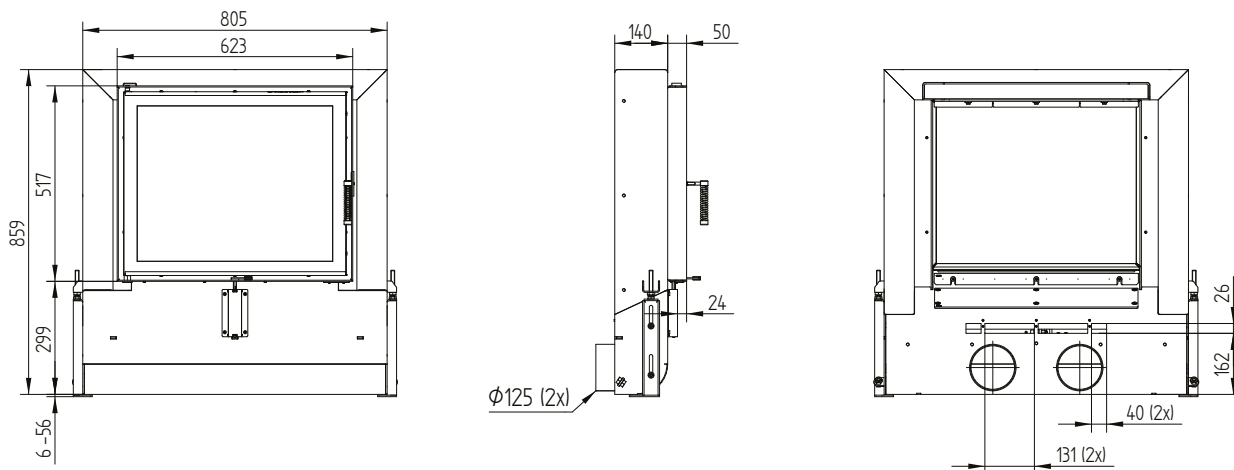

GT2 63/51

Technische Daten
Stand 09/2023

GT2 63/51 mit Grundgestell / FüÙe

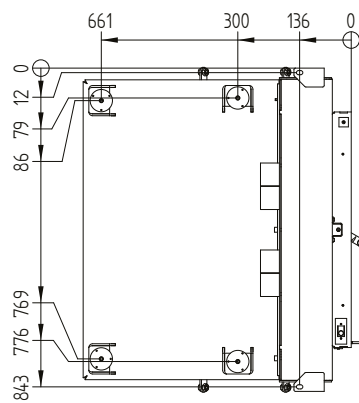
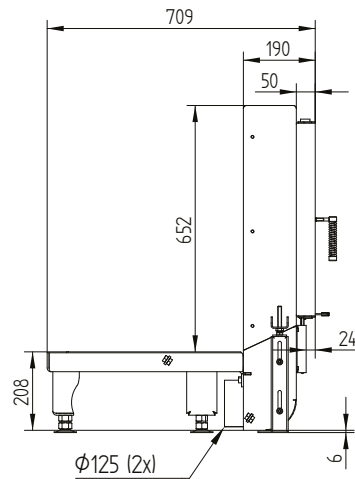
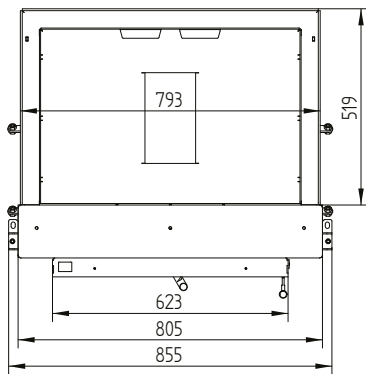

Blendrahmen 63/51 4seitig 50 mm 1 x 90°

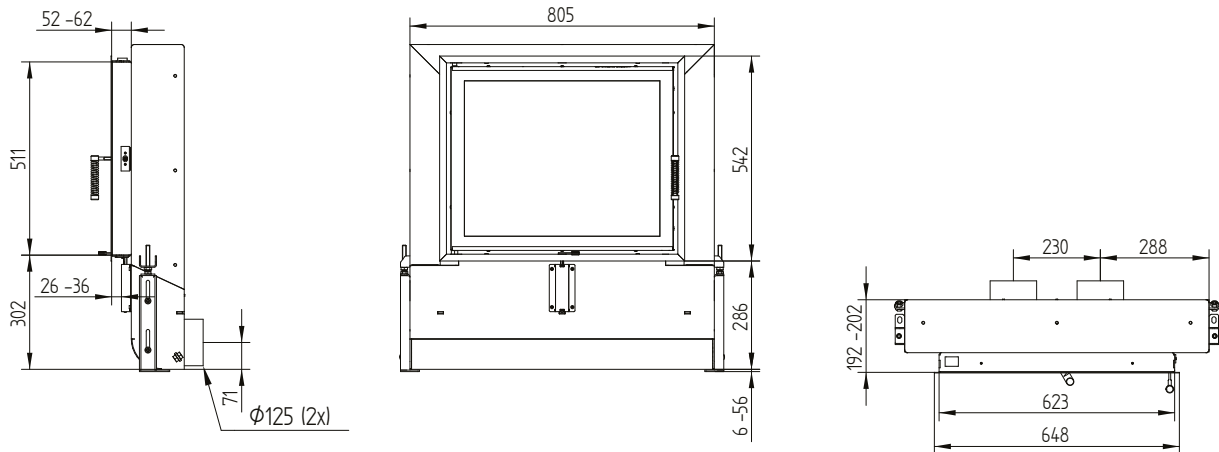

Blendrahmen 63/51 4seitig 80 mm 2 x 45°

